



Designation: E2443 – 05 (Reapproved 2018)<sup>ε1</sup>

## Standard Guide for Verifying Computer-Generated Test Results Through The Use Of Standard Data Sets<sup>1</sup>

This standard is issued under the fixed designation E2443; the number immediately following the designation indicates the year of original adoption or, in the case of revision, the year of last revision. A number in parentheses indicates the year of last reapproval. A superscript epsilon ( $\epsilon$ ) indicates an editorial change since the last revision or reapproval.

---

<sup>ε1</sup> NOTE—Sections 3.1.2, 3.1.4, 4.2, 4.7.3, 4.8.4, and 4.10 were editorially corrected in August 2018.

---

### 1. Scope

1.1 This guide establishes a process for the verification of application software used to calculate the mechanical properties of materials.

1.2 This guide has two purposes: (1) it provides guidelines for creating standard data sets for verifying computer-generated test results, and (2) it describes how users can verify whether the calculations in their application software produce accurate, acceptable results. This does not ensure that the software will produce correct results in all cases. The verification is only for those conditions covered by the standard data sets. This guide uses the concept of standard “data sets,” which are made available by the ASTM groups responsible for each of the individual standards.

1.3 This guide defines the terminology, the format, and the process for the use of these data sets and how the data sets are to be used for verification. It does not define the specific data sets required to verify each of the application standards. Rather, such data sets would become a necessary part of the standard and would be classified as an adjunct in accord with the definition in section B29 of the “Form and Style for ASTM Standards.” This classifies an adjunct as any material that is required for use of the standard but is not practicable to publish as an integral part of the standard.

1.4 In **Annex A1** there is an example of how such data sets would be made available for one example standard.

1.5 Because the verification data sets are contained in files supplied to the application software in the computer, this procedure only provides verification of post-test calculations performed by the computer system. It does not evaluate the data acquisition system, real-time calculations, or any other part of the software beyond the post-test calculations.

1.6 *This international standard was developed in accordance with internationally recognized principles on standardization established in the Decision on Principles for the Development of International Standards, Guides and Recommendations issued by the World Trade Organization Technical Barriers to Trade (TBT) Committee.*

### 2. Referenced Documents

2.1 *ASTM Standards:*<sup>2</sup>

E1942 [Guide for Evaluating Data Acquisition Systems Used in Cyclic Fatigue and Fracture Mechanics Testing](#)

### 3. Terminology

3.1 *Definitions of Terms Specific to This Standard:*

3.1.1 *ASCII*—American National Standard Code for Information Interchange. Data supplied in this form is readable by any computer system and will be displayed on the screen in human readable form.

3.1.2 *raw data*—The sampled values of a sensor output.

3.1.3 *data set*—A self-contained set of data consisting of a preamble, specimen information, and basic data. This may take the form of a printed document or a computer data file.

3.1.4 *derived data*—Data obtained through the processing of the raw data.

3.1.5 *expected results*—The results accompanying the data sets that are expected from the computer.

3.1.6 *item separator*—A special character (delimiter) used to separate items that appear on one line of ASCII characters.

3.1.7 *keyword*—A text word or combination of characters that uniquely identify an item of information in the Specimen Information section. Such keywords are defined in a preamble to the data set within the standard in which they are to be used.

3.1.8 *line terminator*—A character or sequence of characters used to signify the end of a line of ASCII characters.

---

<sup>1</sup> This guide is under the jurisdiction of ASTM Committee E08 on Fatigue and Fracture and is the direct responsibility of Subcommittee E08.03 on Advanced Apparatus and Techniques.

Current edition approved June 1, 2018. Published August 2018. Originally approved in 2005. Last previous edition approved in 2010 as E2443-05. DOI: 10.1520/E2443-05R18E01.

---

<sup>2</sup> For referenced ASTM standards, visit the ASTM website, [www.astm.org](http://www.astm.org), or contact ASTM Customer Service at [service@astm.org](mailto:service@astm.org). For *Annual Book of ASTM Standards* volume information, refer to the standard’s Document Summary page on the ASTM website.

3.1.9 *preamble*—A text section describing the data set, which standard it applies to, any critical information and restrictions for use of the data sets, and the expected values (derived data) to be found as a result of running the algorithm using the basic data. This section of the data set would not be used by the computer, and would normally be stripped off of the data set prior to its use with the computer.

3.1.10 *segment marker*—A column of data alongside the columns of basic data which indicate different control sections during the test, such as loading versus unloading sections, which might be needed by the algorithm under evaluation.

3.1.11 *specimen information*—Information about a tested specimen, other than the basic data, such as specimen dimensions, speed of testing, and any other relevant information that are required in the analysis.

3.1.12 *status*—The status of the standard data set indicates that it has either been approved by the appropriate ASTM entity, or that it is unapproved. Unapproved data sets may be posted and made available to users for round robin testing or other purposes, but results from the use of an unapproved data set would not meet the requirements of this standard guide.

#### 4. Description of the Use of Basic Data For Software Verification.

4.1 In its most basic form, a mechanical testing system consists of a test frame with grips which attach to a test specimen, a method of applying forces to the specimen, and a number of transducers that measure the forces and deformations applied to the specimen. (See Fig. 1)

4.2 The measurement system may be divided into three sections for the purpose of verification: the mechanical test frame and its components, the electrical measurement system, and the computer processing of data. This guide is specifically

concerned only with the final section, namely the computer processing of data once the basic data is acquired.

4.3 The principle of using data sets is that a standard may publish as an adjunct a set of basic data and expected results that may be used to verify that software designed to implement the calculations is performing correctly. The user of the data set inputs such data into their computer either automatically, manually, or a combination of both.

4.3.1 For example, it may prove most convenient to input the specimen information (described in 4.7) manually, and then have the computer read the basic data as a file. The user then starts the computation and compares the actual results with expected results supplied along with the data set. If such results agree with the expected results within the specified tolerance, the computer algorithms may be considered verified. If not, the user must explore the reason for the difference.

4.4 When supplied in the form of a computer-readable file, the data set shall be in industry-standard ASCII format.

4.5 *Preamble Characteristics*—The preamble to the data set is a section of text containing at least the following:

4.5.1 Unique ID of the form: ASTM standard number to which this data set applies, DSxx, where xx is the data set number (revision year.) For example, E 1234-DS2(2005);

4.5.2 Title;

4.5.3 Any parameters required by the algorithm, and the units to be used;

4.5.4 Short description of the content of the data file and what test conditions this data set is verifying;

4.5.5 Details of the segment markers on the data file, if any;

4.5.6 Expected results (in appropriate units), as well as the allowable tolerance (in %); and

4.5.7 Contact information for ASTM International.

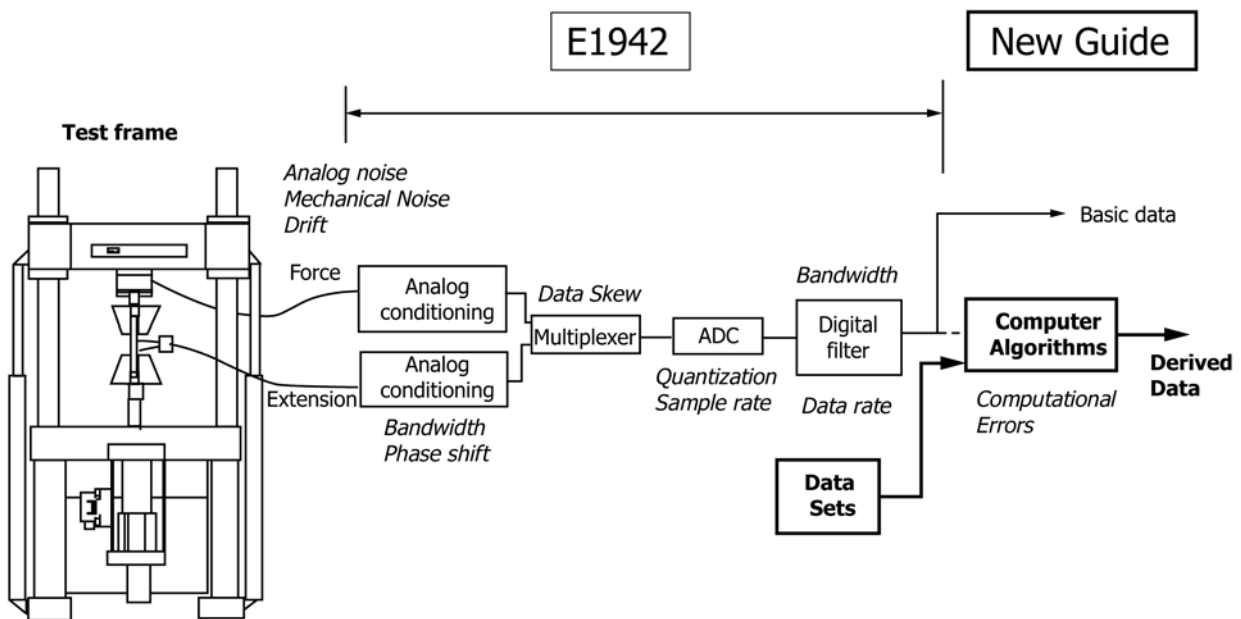

FIG. 1 Schematic of a typical test system